

Problem Set

Repetition

- Draw the energy level diagram for a two spin system and include all possible transitions.
 - Why are not all transitions between energy levels in a two spin system allowed?
 - What is the difference between scalar and dipolar coupling?
 - What is the favourite orientation of two nuclear spins in i) one-bond and ii) two-bonds.
 - Describe the difference between magnetic and chemical equivalence.
 - Why are there exactly 16 product operators for 2 spins 1/2.
 - Write down the four effects that contribute to the chemical shielding.
 - Why are the Hamiltonians for J-coupling the same in the laboratory and rotating frame?
-

Problem 1 : J coupling

The J coupling does not depend on the absolute value of B_0 but on the characteristics of the nuclei involved and in particular of the bonding electrons between them. Chemical shifts on the other hand are directly related to relative Larmor frequencies ω_0 , and so do depend on B_0 . Let us illustrate this with part of the spectrum of trans 3-phenyl propenoic acid (Fig. 1), which gives rise to a so called two-spin system. The spin system is referred to as AB if the chemical shifts are quite close together, and AX if they are far apart. Since J couplings depends on the intervening bonds and electrons, its value is highly characteristic of these bonds. In this case the coupling arises from three intervening bonds, and hence we term it $^3J_{\text{H-H}}$ coupling. Typical values for this type of J coupling are indicated by the arrow.

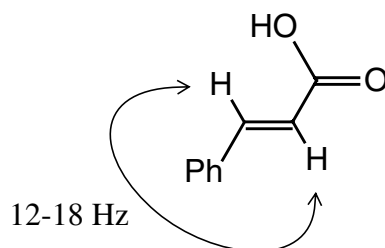

Figure 1: Chemical structure of trans 3-phenyl propenoic acid.

- Write the two-spin Hamiltonian for the two protons in the rotating frame.
- Calculate the NMR spectra (frequencies and intensities) following the discussion in the script.
- Assuming a relative chemical shift of 2 ppm for the two protons and a coupling constant $J_{12}=16$ Hz, plot the spectra at different values of B_0 , corresponding to proton Larmor frequencies of $\omega_0 = 60, 100, 300, 600,$ and 1000 MHz.
- Comment on the differences between the 600 MHz and the 60 MHz spectra.
- How do the spectra change if the coupling is a dipolar coupling?

Problem 2 : Off-resonance decoupling

We consider a heteronuclear two-spin system with chemical shifts S and I and a J coupling J_{IS} . The spin system is irradiated on the I spin with an rf-field of amplitude ω_{1I} .

- Write down the full Hamiltonian of the spin system in the rotating frame.

The situation described by this Hamiltonian corresponds to off-resonance decoupling where the J coupling is scaled but not fully averaged to zero. To calculate the scaling factor, we transform the Hamiltonian into a tilted frame where the z-axis of the I spin is along the effective field on the I spin.

- Calculate the angle and the length of the effective field on the I spin.
- Rotate the Hamiltonian around the y axis such that the z axis of the I spin is along the effective field direction.
- What form has the Hamiltonian in this coordinate system.

To calculate the scaling factor of the J coupling, we transform the Hamiltonian into an interaction frame around the effective field of the I spin.

- Which term becomes time dependent in the Hamiltonian of question d?

We can neglect all time dependent terms. This leads to an approximate effective Hamiltonian that describes the residual off-resonance coupling.

- Plot the residual coupling as a function of the chemical-shift offset of the I spin (Ω_I) for an rf-field amplitude of $\omega_{1I}/(2\pi) = 500$ Hz.
- What is the functional form of the scaling factor if we assume $\omega_{1I} \gg \Omega_I$

Problem 3 : Operator representations

For certain NMR experiments the “flip-flop” term ($\hat{I}_1^+ \hat{I}_2^- + \hat{I}_1^- \hat{I}_2^+$) is important for describing the time evolution of the (two) spin system.

- Write this term in Cartesian operators.
- Calculate the matrix representation of this spin term using the direct product and the matrix representations of the raising and lowering operators for the single spins.
- How does this term look in spherical tensor operator notation?
- How would you generate this term if you would use the expression for the tensor product of two spherical tensors?

Problem 4 : Tensor Rotations

Assume a ^{13}C chemical shift tensor with principal values given by $\sigma_{11}=223$, $\sigma_{22}=75$, and $\sigma_{33}=61$ ppm.

- Write the chemical shift tensor in its Principle Axis System (PAS) in cartesian notation.
- Write the chemical shift tensor in its PAS in spheric harmonic notation.

We define a new reference frame in which is related to the original frame by a 90 degree rotation around the y-axis.

- What is the rotation matrix needed to perform this transformation?
- What are the Euler angles describing the same rotation.
- Write the cartesian tensor in this new frame.
- Write the spheric tensor in this new frame.

Problem 5 : Chemical Shift

- [18]-Annulene (*Figure 2*) is an aromatic molecule with $(4n + 2)$ π -electrons. At low temperature (213 K) the solution state ^1H NMR spectrum shows two signals. Make a sketch of the spectrum, including the approximate chemical shifts (in ppm) relative to TMS and the correct relative intensities.

- b. Give an explanation for the chemical shifts of the two resonances of annulene. Would you expect to find the signal due to the outer protons to be upfield or downfield from the signal of the protons in benzene (~ 7.3 ppm)? Why?

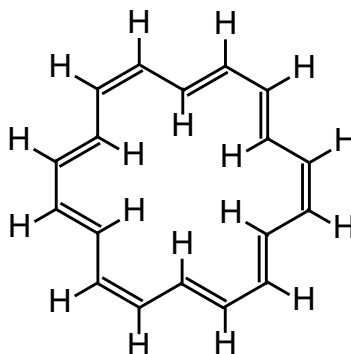

Figure 2: Structure of [18]-annulene.

Problem 6 : Single Crystal and MAS

In the first part of this problem you will calculate the resonance frequency of a ^{13}C spin in a single crystal. The ^{13}C will be the carbonyl group of Alanine. The principle components of the ^{13}C chemical shift tensor of this group are $\sigma_{11} = 239$, $\sigma_{22} = 184$ and $\sigma_{33} = 106$ ppm. The orientation of the crystal is such that the vectors corresponding to the principle components lie along \mathbf{x} , \mathbf{y} and \mathbf{z} in the laboratory frame and $\vec{B}_0 \parallel \mathbf{z}$.

- What is the expression describing the resonance frequency (in ppm) for this orientation of the crystal?
- The crystal is rotated by an angle γ around an arbitrary axis. The rotation axis has the spherical polar coordinates $\phi = 0$ and $\theta = \arccos(1/\sqrt{3}) \approx 54.7356^\circ$. The rotation matrix corresponding to this rotation is:

$$R(\gamma) = \begin{bmatrix} \frac{1}{3}(2 + \cos\gamma) & \frac{-\sin\gamma}{\sqrt{3}} & \frac{\sqrt{2}}{3}(1 - \cos\gamma) \\ \frac{\sin\gamma}{\sqrt{3}} & \cos\gamma & -\frac{\sqrt{2}}{3}\sin\gamma \\ \frac{\sqrt{2}}{3}(1 - \cos\gamma) & \frac{\sqrt{2}}{3}\sin\gamma & \frac{1}{3}(1 + 2\cos\gamma) \end{bmatrix} \quad [1]$$

The inverse matrix is obtained by replacing γ with $-\gamma$, i.e. $R^{-1}(\gamma) = R(-\gamma)$. Calculate the resonance frequency as a function of γ and make a “rotation plot”. Keep in mind that you only have to calculate one element of the chemical shift tensor. Express your result in the form $\sigma(\gamma) = \sigma_{\text{iso}} + \sigma_1 \cos\gamma + \sigma_2 \cos 2\gamma$. What are the values for σ_{iso} , σ_1 and σ_2 ?

c. Show that σ_{iso} has the same value as the chemical shift in the liquid state.

In many cases it is difficult to obtain big, high quality, single crystals of a given molecule. It is often much easier to get an amorphous or micro crystalline powder.

Assume that you have a powdered sample of Alanine in which the orientation of the chemical shift tensor with respect to the magnetic field is random. Also assume that the values for the principle components of the chemical shift are unchanged.

d. Make a sketch of the ^{13}C spectrum of the carbonyl group in this powdered sample of Alanine. What is the main difference between the spectrum from the single crystal and the powder?

e. What happens if you rotate continuously, i.e. if $\gamma(t) = 2\pi\omega_r \cdot t$, where ω_r is the rotation frequency. What is the mathematical expression for the signal and how does the spectrum look like (schematically)? For simplicity assume that you once more have the single crystal of Alanine used in question a-c.

Hint: First consider the case that the rotation is fast. For slow or intermediate rotation, remember that you can use the following expansion:

$$\exp(i \cdot z \cdot \sin(\theta)) = \sum_{k=1}^{\infty} (i)^k \cdot J_k(z) \cdot \exp\left(ik\left(\theta + \frac{\pi}{2}\right)\right) \quad [2]$$

Where $J_k(z)$ is a Bessel function of the first kind of order k .

The type of rotation described in the last exercise is actually possible and done routinely in solid-state NMR. The sample is loaded in a rotor which is rotated around an axis which is inclined with respect to the magnetic field by an angle of 54.7° . This angle is called the Magic Angle and consequently the technique is known as Magic Angle Spinning (MAS).

The maximum rate of rotation depends on the diameter of the rotor and varies from ~ 10 Hz up to 70 kHz. To achieve these spinning rates compressed air is used to drive the rotor. The air is also used to create a bearing which levitates the rotor on a cushion of air. In practice not single crystals are spun but powdered samples of the type described for question d.

A schematic picture of a typical MAS stator and rotor are shown in *Figure 3*. The figure is approximately on a 1:1 scale.

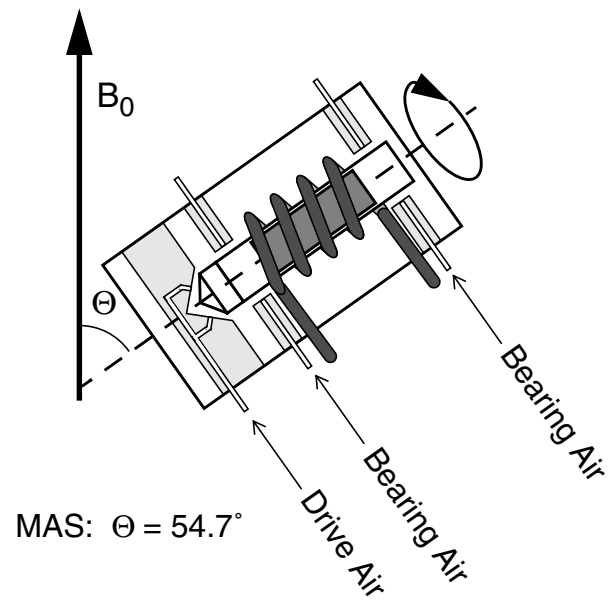

Figure 3: Schematic drawing of a MAS stator and rotor.